

Single 25A Full Wave Rectifier MT200 — MT800

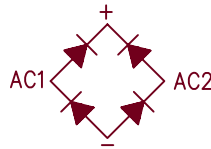

Note: Electrically Isolated

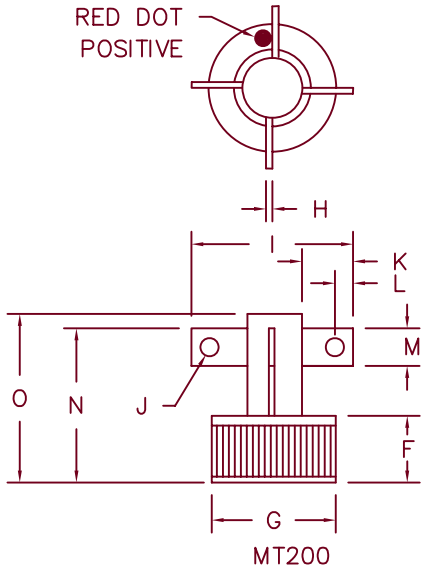
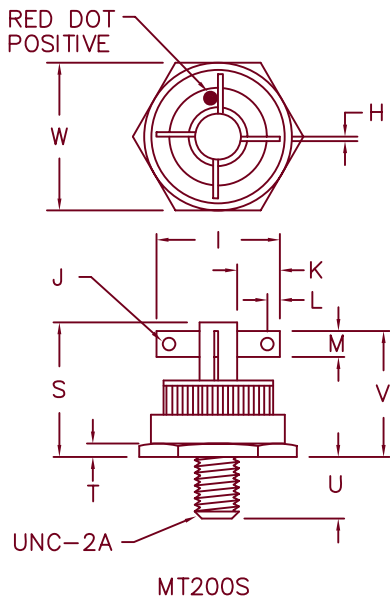
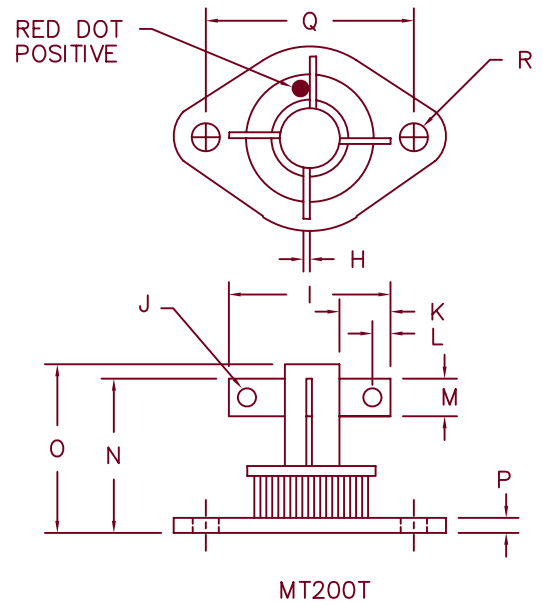

Dim.	Inches		Millimeter		Notes
	Minimum	Maximum	Minimum	Maximum	
F	.390	.420	9.90	10.67	
G	.751	.755	19.07	19.18	
H	---	.032 typ.	---	---	
I	---	1.0	---	25.4	
J	---	.11 typ.	---	---	Dia.
K	.250	---	6.35	---	
L	---	.125 Typ.	---	---	
M	---	.187 Typ.	---	---	
N	---	.830	---	21.08	

Dim.	Inches		Millimeter		Notes
	Minimum	Maximum	Minimum	Maximum	
O	---	.930	---	23.62	
P	---	.135	---	3.43	
Q	1.177	1.197	29.90	30.40	
R	.151	.161	3.84	4.10	Dia.
S	---	1.20	---	30.48	
T	---	.125 typ.	---	---	
U	.340	.400	8.64	10.16	
V	---	1.10	---	27.94	
W	---	.875	---	22.83	



6 Lake Street
Lawrence, MA 01841
PH: (978) 620-2600
FAX: (978) 689-0803
www.microsemi.com

05-01-07 Rev. 1

MT200 — MT800

Microsemi
Catalog Number

MT200
MT400
MT600
MT800

Repetitive Peak
Reverse Voltage

200V
400V
600V
800V

- Glass Passivated Die
- Hermetically sealed
- Soft Recovery
- 200°C Junction temperature
- 2000VDC Isolation voltage

Electrical Characteristics

DC forward current output
Maximum Surge Current
Maximum I^2t For Fusing
Max. Peak Forward Voltage per leg
Max. Peak Reverse Current
Max. Peak Reverse Current

I_o 25A
 I_{FSM} 200 Amps
 I^2t 165A²s
 V_{FM} 1.3 Volts
 I_{RM} 10 μ A
 I_{RM} 1.0 mA

$T_C = 130^\circ\text{C}$
8.3mS, half sine, $T_C = 130^\circ\text{C}$
 $I_{FM} = 25\text{A}; T_J = 25^\circ\text{C}$
 V_{RM} rated, $T_J = 25^\circ\text{C}$
 V_{RM} rated, $T_J = 150^\circ\text{C}$

Thermal and Mechanical Characteristics

Storage temperature range
Operating junction temperature range
Max thermal resistance per package

T_{STG}
 T_{OP}
 $R_{\theta JC}$

-65°C to $+200^\circ\text{C}$
 -65°C to $+200^\circ\text{C}$
1.0°C/W

MT200 — MT800

Figure 1
Maximum Forward Characteristics

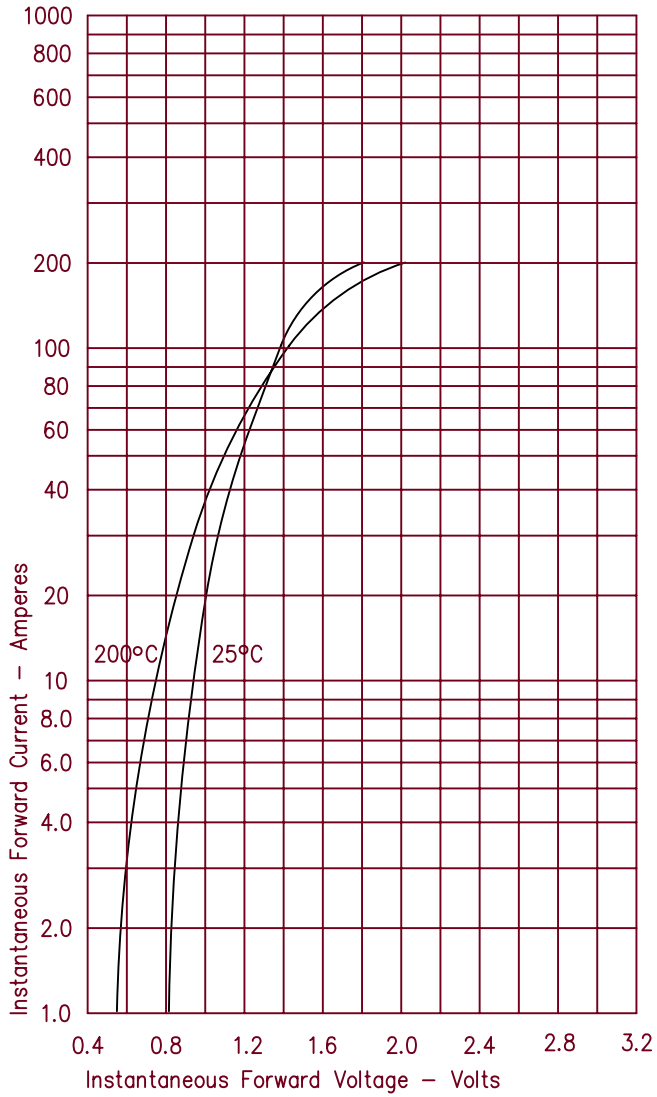

Figure 3
Forward Current Derating

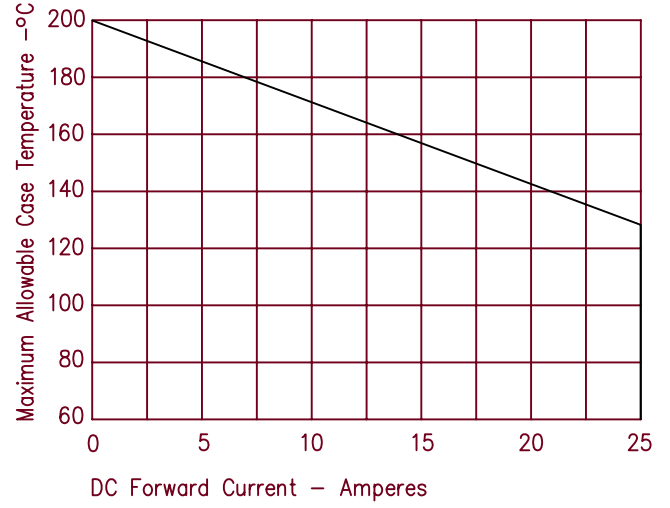

Figure 2
Typical Reverse Characteristics

