

3 Amp Schottky Rectifier LSM335 — LSM345

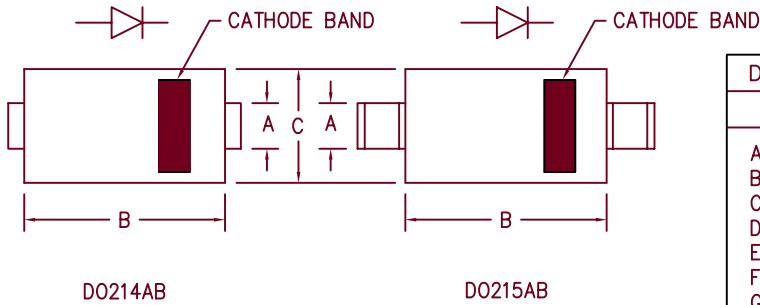

Dim.	Inches		Millimeter		Notes
	Minimum	Maximum	Minimum	Maximum	
A	.117	.123	2.97	3.12	
B	.260	.280	6.60	7.11	
C	.220	.245	5.59	6.22	
D	.307	.322	7.80	8.18	
E	.075	.095	1.91	2.41	
F	.380	.400	9.65	10.16	
G	.025	.040	.640	1.02	
H	.030	.060	.760	1.52	

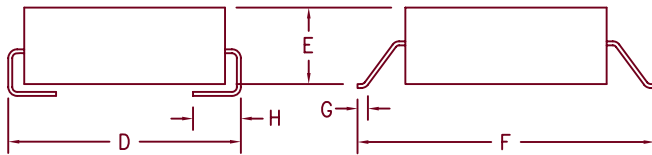

Microsemi Catalog Number	Industry Part Number	Working Peak Reverse Voltage	Repetitive Peak Reverse Voltage
LSM335*		35V	35V
LSM340*	30BQ040 15MQ040N MBRS340TR	40V	40V
LSM345*		45V	45V

* Add Suffix J for J Lead or G for Gull Wing Lead Configuration

- Schottky Barrier Rectifier
- Guard ring protection
- Low forward voltage
- 150°C Junction temperature
- Reverse energy tested

Electrical Characteristics

Average forward current	I _{F(AV)} 3.0 Amps	Square wave
Maximum surge current	I _{FSM} 150 Amps	8.3ms, half sine, T _J = 150°C
Max peak forward voltage	V _{FM} .45 Volts	I _{FM} = 1.0A; T _J = 25°C *
Max peak forward voltage	V _{FM} .52 Volts	I _{FM} = 3.0A; T _J = 25°C *
Max peak forward voltage	V _{FM} .76 Volts	I _{FM} = 9.4A; T _J = 25°C *
Max peak reverse current	I _{RM} 1.5 mA	V _{RRM} , T _J = 25°C
Typical junction capacitance	C _J 265 pF	V _R = 5.0V, T _J = 25°C

*Pulse test: Pulse width 300 μsec, Duty cycle 2%

Thermal and Mechanical Characteristics

Storage temperature range	T _{STG}	-55°C to 175°C
Operating junction temp range	T _J	-55°C to 150°C
Maximum thermal resistance	RO _{JL}	25°C/W Junction to lead
Weight		.008 ounces (.22 grams) typical



8700 East Thomas Road, P.O. Box 1390
Scottsdale, AZ 85252
PH: (480) 941-6300
FAX: (480) 947-1503
www.microsemi.com

05-17-07 Rev. 3

LSM335 — LSM345

Figure 1
Typical Forward Characteristics

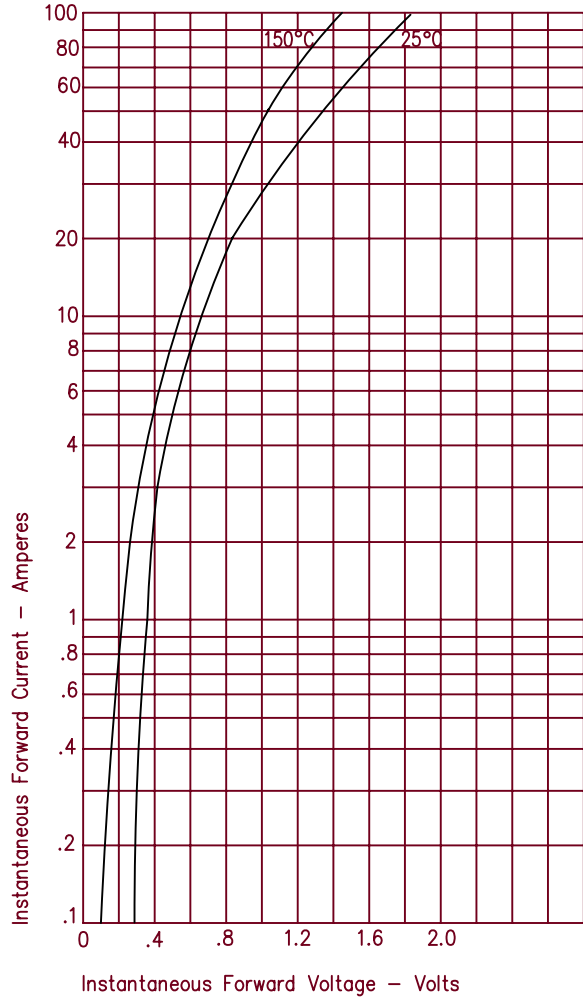

Figure 3
Typical Junction Capacitance

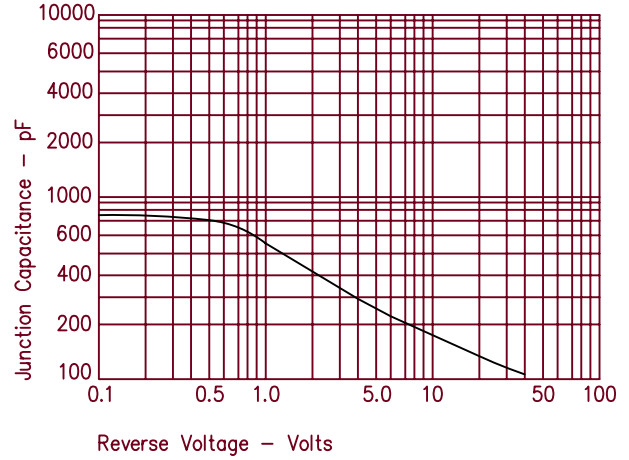

Figure 2
Typical Reverse Characteristics

