

Ultra Fast Recovery Rectifiers

UFS530 — UFS550

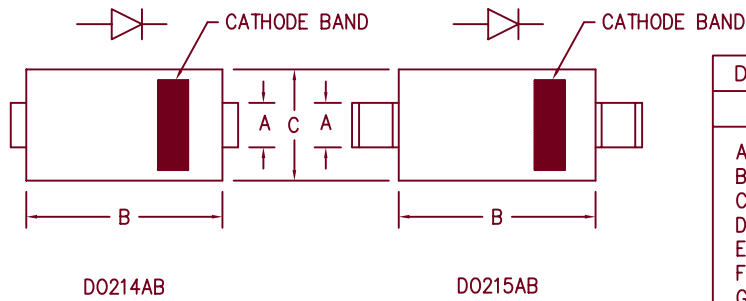

Dim.	Inches		Millimeter		Notes
	Minimum	Maximum	Minimum	Maximum	
A	.117	.123	2.97	3.12	
B	.260	.280	6.60	7.11	
C	.220	.245	5.59	6.22	
D	.307	.322	7.80	8.18	
E	.075	.095	1.91	2.41	
F	.380	.400	9.65	10.16	
G	.025	.040	.640	1.02	
H	.030	.060	.760	1.52	

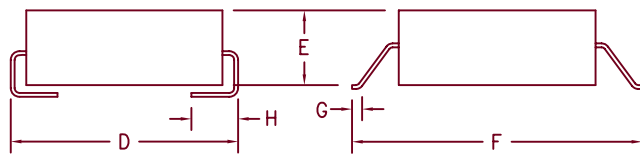

Microsemi Catalog Number	Working Peak Reverse Voltage	Repetitive Peak Reverse Voltage
*UFS530	300V	300V
*UFS540	400V	400V
*UFS550	500V	500V

* Add Suffix J for J Lead or G for Gull Wing Lead Configuration

- Ultra Fast Recovery
- 175°C Junction Temperature
- VRRM 300 to 500 Volts
- 5 Amp current rating
- t_{RR} 50nS Max.

Electrical Characteristics		
Average forward current	I _{F(AV)} 5.0 Amps	Square wave
Maximum surge current	I _{FSM} 175 Amps	8.3ms, half sine, T _J = 175°C
Max peak forward voltage	V _{FM} 1.2 Volts	I _{FM} = 5.0A: T _J = 25°C*
Max reverse recovery time	t _{RR} 50 nS	1/2A, 1A, 1/4A, T _J = 25°C
Max peak reverse current	I _{RM} 10 μ A	V _R = 10V, T _J = 25°C
Typical junction capacitance	C _J 28 pF	

*Pulse test: Pulse width 300 μ sec, Duty cycle 2%

Thermal and Mechanical Characteristics		
Storage temperature range	T _{STG}	-55°C to 175°C
Operating junction temp range	T _J	-55°C to 175°C
Maximum thermal resistance	R θ JL	22°C/W Junction to lead
Weight		.008 ounces (.22 grams) typical



8700 East Thomas Road, P.O. Box 1390
 Scottsdale, AZ 85252
 PH: (480) 941-6300
 FAX: (480) 947-1503
www.microsemi.com

05-08-07 Rev. 2

UFS530 — UFS550

Figure 1
Typical Forward Characteristics

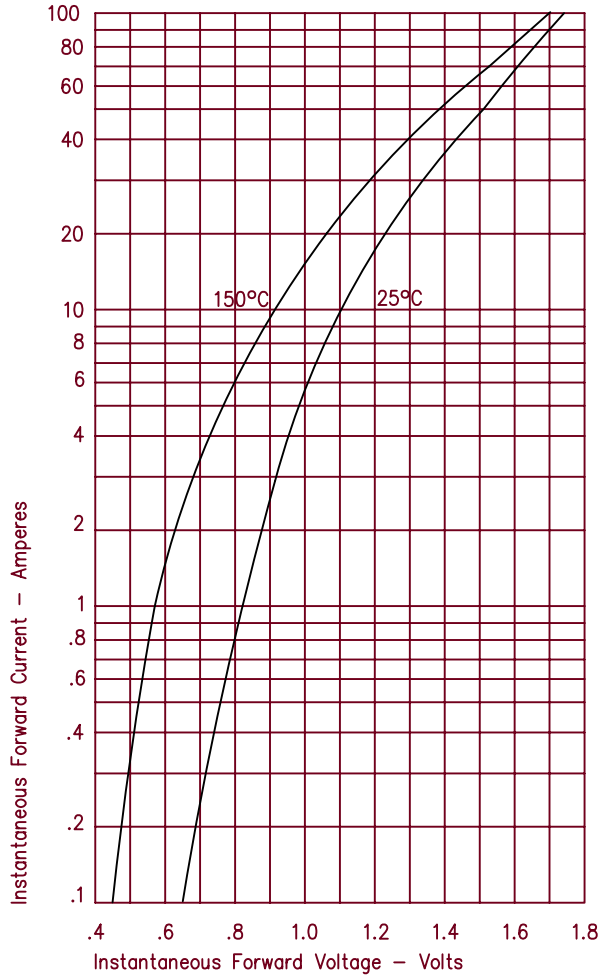

Figure 3
Typical Junction Capacitance

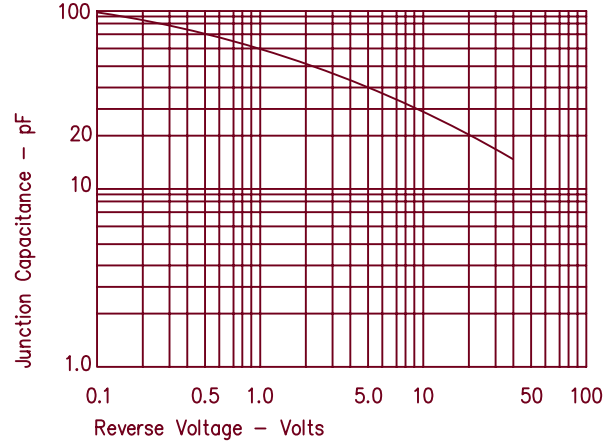

Figure 2
Typical Reverse Characteristics

