

High Brightness Step-Down LED Driver Demoboard with Excellent Current Regulation

General Description

The HV9911DB3 is an LED driver capable of driving up to 25 one-watt LEDs in series from an input of 130 - 200VDC. The demoboard uses Supertex's HV9911 in a buck topology with the HV7800 used for high side current sensing. The converter has a very good initial regulation (+/-5%) and excellent line and load regulation over the entire input and output voltage range (<+/-2%). The full load efficiency of the converter is typically greater than 85%.

The HV9911DB3 is protected against open LED and output short circuit conditions. It is also protected from input under voltage conditions. It has a very good PWM dimming response, with typical rise and fall times of less than 5.0 μ s, which will allow high PWM dimming ratios.

The switching frequency of the HV9911DB3 can be synchronized to other HV9911 boards or to an external 150kHz clock by connecting the clock to the SYNC pin of the HV9911DB3.

Specifications

Parameter	Value
Input voltage (steady state):	130 - 200VDC
Output LED string voltage:	20V min - 100V max
Average output current:	350mA +/-5%
Output current ripple:	5% typical
Switching frequency:	150kHz
Full load efficiency:	90% (at 150V input)
Output short circuit protection:	Included
Input under voltage protection:	Included
PWM dimming performance:	5.0 μ s (rise time) 5.0 μ s (fall time)
Dimensions:	53.7mm x 38.1mm

Board Layout and Connection Diagram



Actual Size: 53.7mm X 38.1mm

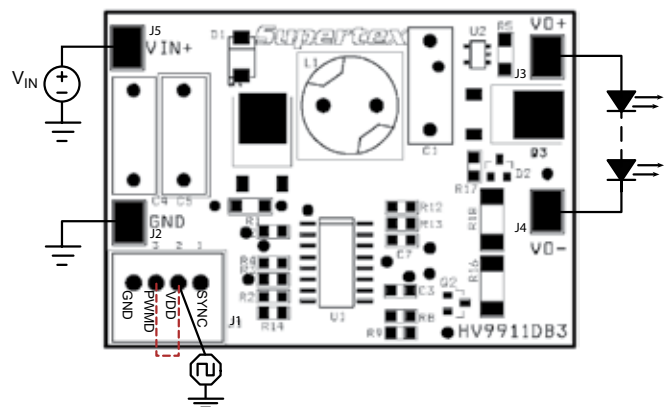

Connections:

Input - The input is connected between the VIN+ and GND terminals as shown.

Output - The output is connected between the VO+ and VO- terminals as shown, with the ANODE of the LED string to VO+ and the CATHODE to connector VO-.

Enable/PWM Dimming - To enable the board, short pins PWMD and VDD of connector J1 as shown. To use the PWM dimming feature of the board, connect an external push-pull square wave source between terminals PWMD and GND of connector J1 as shown by the dotted lines.

SYNC - To synchronize two or more boards, connect the SYNC pins of all the boards. To synchronize the HV9911DB3 to an external 150kHz clock, connect the clock between the SYNC pin and the GND pin of connector J1.

Note:

During PWM dimming, the PWMD pin of connector J1 should be left open. Also, the PWM signal must have the proper polarity, with the positive connected to the VDD pin of connector J1. Note that the GND pin of connector J1 is internally connected to the return path of the input voltage.

Demoboard Testing:

Normal Operation: Connect the input source and the output LEDs as shown in the connection diagram and enable the board. The LEDs will glow with a steady intensity. Connecting an ammeter in series with the LEDs will allow measurement of the LED current. The current will be 350mA +/- 5%.

Current Regulation: While the converter is operating, change the input voltage within its specified input voltage range. The current output of the HV9911DB3 will remain very steady over the entire line range. With the supply turned off, change the number of LEDs in the string within the specified limits and turn the power supply back on. The current will still be regulated at 350mA.

Open LED Test: The buck converter is inherently protected against open LED conditions since the maximum output voltage is limited to the input voltage. If the LED string is disconnected during operation, the output voltage of the converter will rise and stay at the input voltage level.

Short Circuit Test: When the HV9911DB3 is operating in steady state, connect a jumper across the terminals of the LED string. Notice that the output current will immediately go to zero and the converter will shut down. To restart the HV9911DB3, recycle the input power to the demoboard.

PWM Dimming: With the input voltage to the board disconnected, apply a TTL-compatible, push-pull square wave signal between the PWMD and GND terminals of connector J1 as shown in the connection diagram. Turn the input voltage back on and adjust the duty cycle and/or frequency of the PWM dimming signal. The output current will track the PWM dimming signal. Note that although the converter operates perfectly well at a 1kHz PWM dimming frequency, a wider PWM dimming ratio can be obtained at lower frequencies, like 100Hz or 200Hz.

Effect of the High Side Disconnect Switch

The high side disconnect switch included in the HV9911DB3 disconnects and reconnects the load during PWM dimming. This prevents the output capacitor from having to charge/discharge every cycle, leading to shorter PWM dimming rise and fall times. It also limits the surge current through the output sense resistor during output short circuit conditions. However, the level translator needed to drive the disconnect FET consumes power during normal operation and reduces the overall efficiency of the converter by about 3% at full load. The decision to include or exclude the high side driver should depend on which factor is more important, high PWM dimming or converter efficiency. The following typical results section will show the results for both cases.

Typical Results

1. Efficiency: The efficiency of the converter at various LED string voltages is shown in Fig.1 (measured at the nominal input voltage of 150V). Fig.2 shows the full load efficiency of the converter at varying input voltages. The minimum efficiency of 93% for the converter occurs at 21V input and full load output.

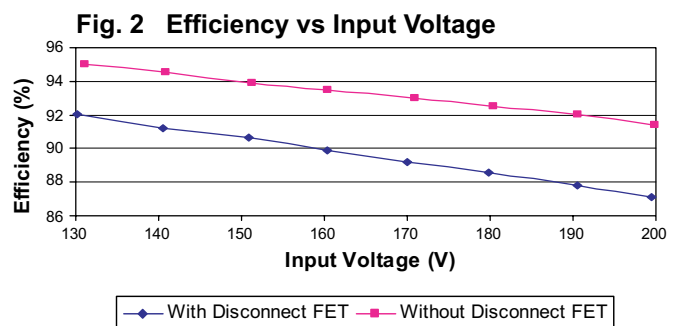
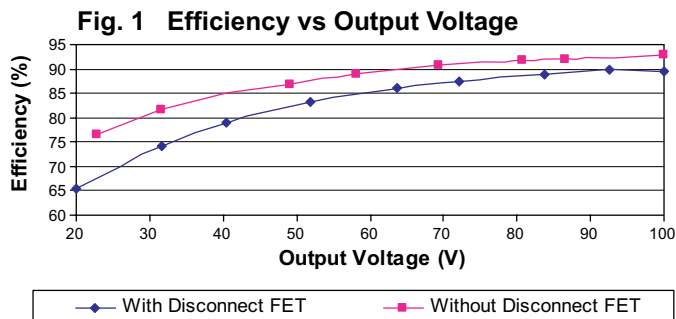

2. Current Regulation: Fig.3 and Fig.4 show the output current regulation vs. output voltage and load voltage, respectively. The total current regulation (line and load combined) is found to be less than 1%.

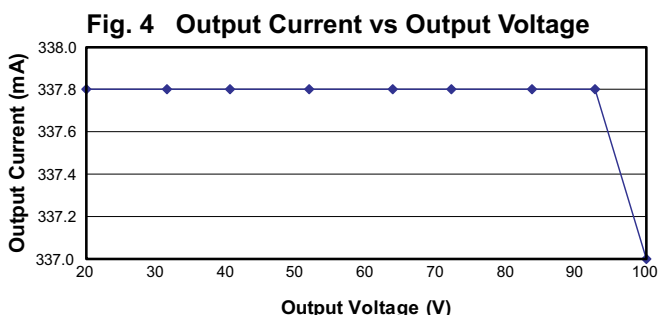
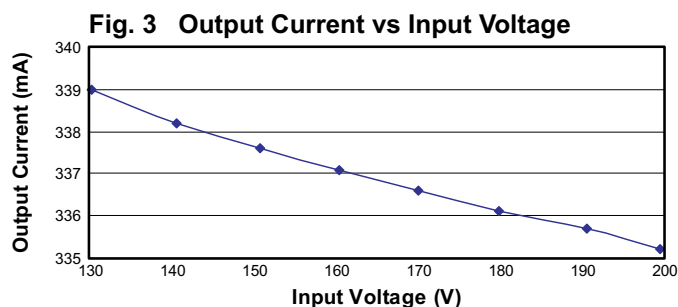

3. Normal Operation: Figs.5a, 5b, and 5c show the drain voltage and output current waveforms during normal operation.

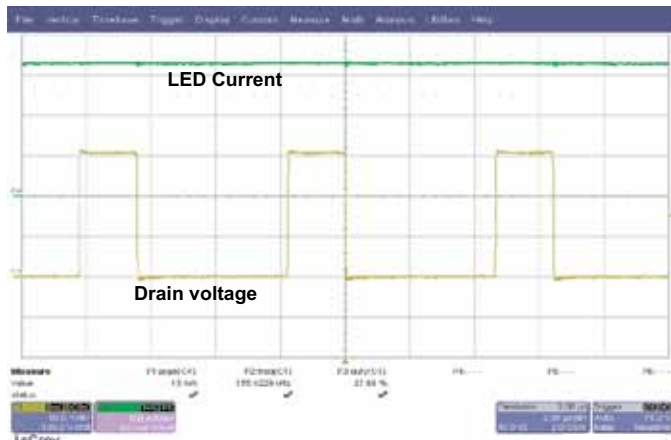

Fig.5a Waveforms at $V_{IN} = 150V$ and $V_O = 100V$

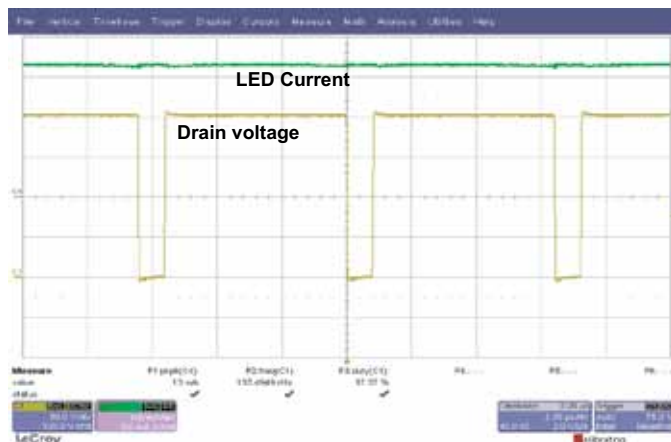

Fig.5a Waveforms at $V_{IN} = 200V$ and $V_O = 20V$

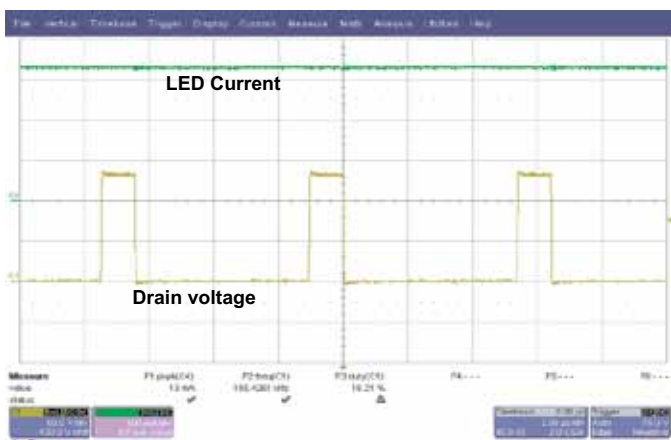

Fig.5a Waveforms at $V_{IN} = 130V$ and $V_O = 100V$

4. Open LED Protection: Open LED protection is inherent for the buck converter, as the maximum output voltage is limited to the input voltage. Fig.6 shows the output voltage, LED current, and the drain voltage of the switching FET when the load is disconnected during normal operation. The FET is always turned on during this time and the output voltage is equal to the input voltage. If the output voltage sags due to current leakage, the FET resumes switching until the input and output voltages become equal.

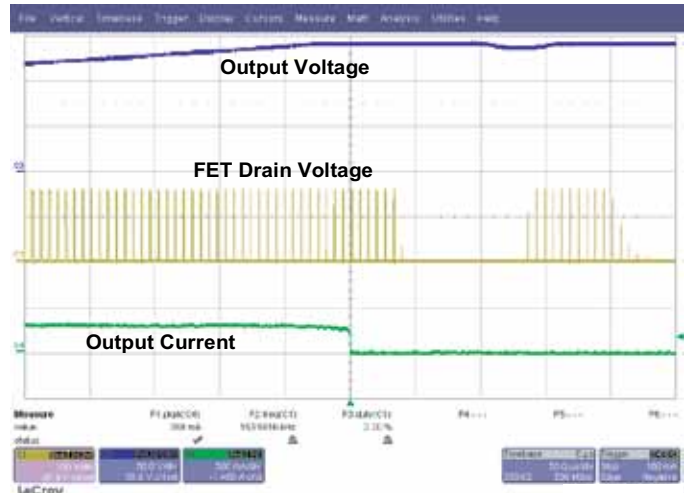

Fig.6 Open LED Protection

5. Output Short Circuit Protection: Fig.7 shows the waveforms for an output short circuit condition. Although the FAULT pin goes to zero in about 300ns and the switching is terminated, the time taken for the disconnect FET to turn off (and the current to go to zero) will depend on the RC time constant of the resistor R17 (refer to schematic diagram) and the C_{GS} of the disconnect FET. In this case, the disconnect FET is turned off in about 3 μ s. The rise in the output current will depend on the saturation current of the disconnect FET.

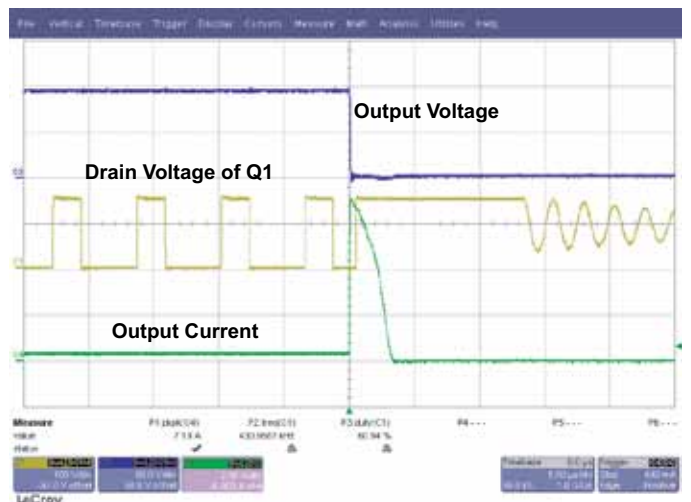
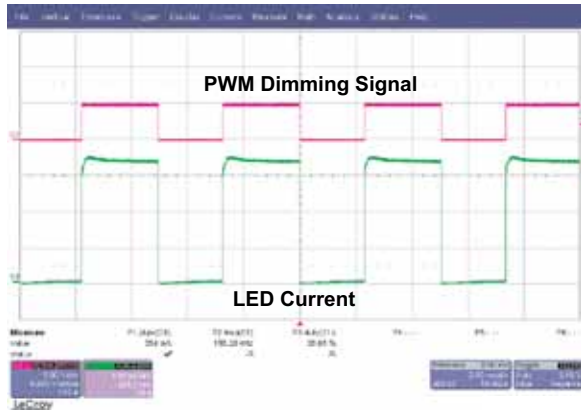

Fig.7 Output Short Circuit Protection

6. PWM Dimming: Typical PWM dimming response is shown in Fig.8. Fig.9 shows the rise and Fig.10 shows the fall of the LED current on an expanded time scale. For comparison, the waveforms are shown with and without the disconnect FET.

Fig. 8 Typical PWM Dimming Response



(8a) with disconnect FET

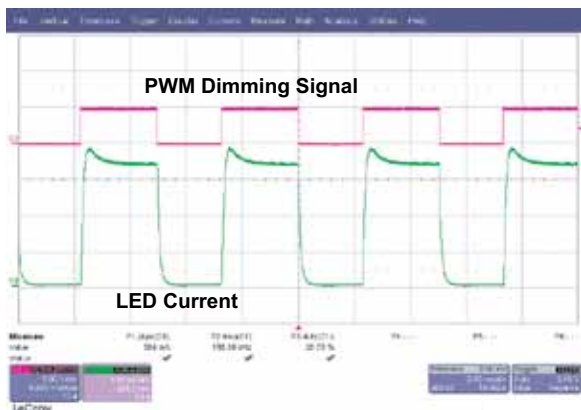

(8b) without disconnect FET

Fig.9 Rise Time for PWM Dimming Response

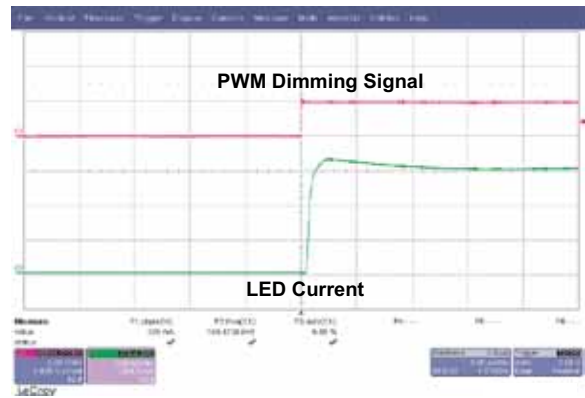

(9a) 5 μ s - with disconnect FET

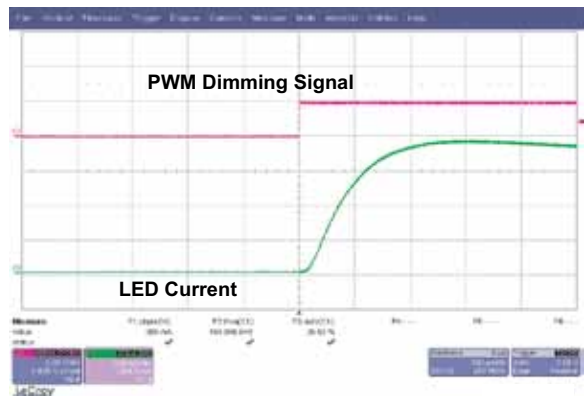

(9b) 300 μ s - without disconnect FET

Fig.10 Fall Time for PWM Dimming Response

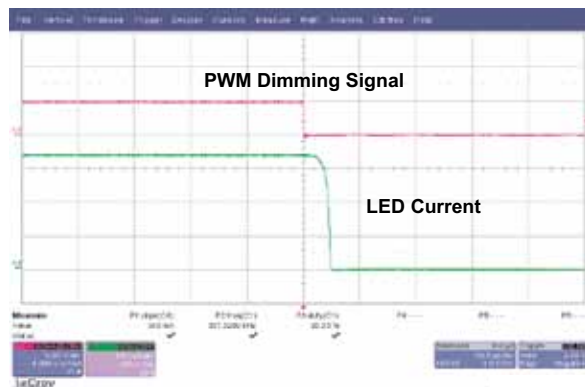

(10a) 5 μ s - with disconnect FET

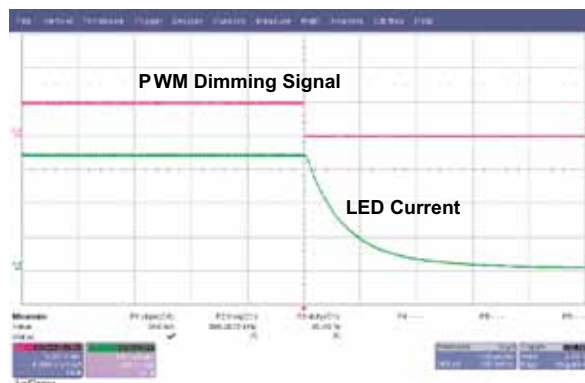

(10b) 300 μ s - without disconnect FET

Circuit Schematic:

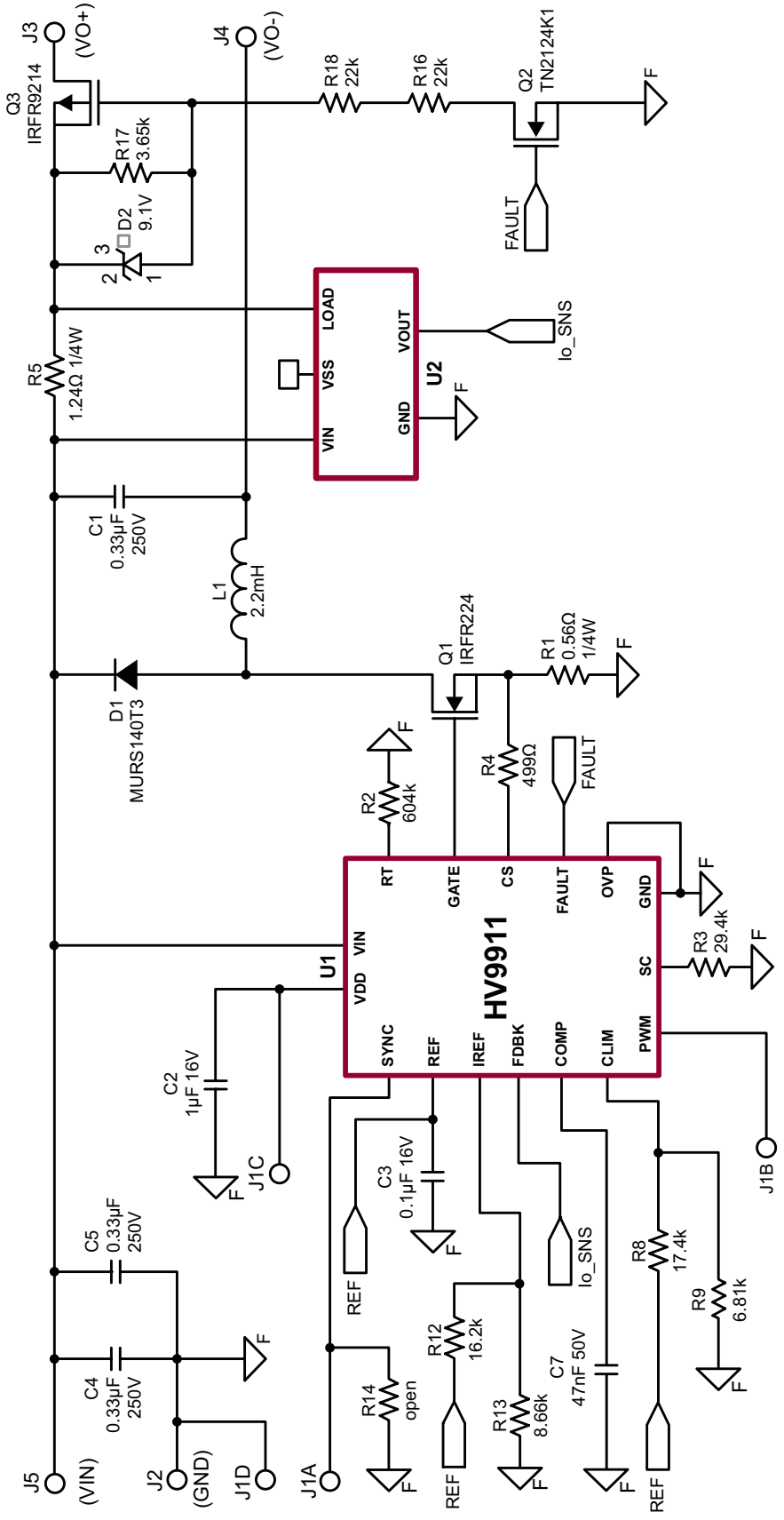

Silk Screen

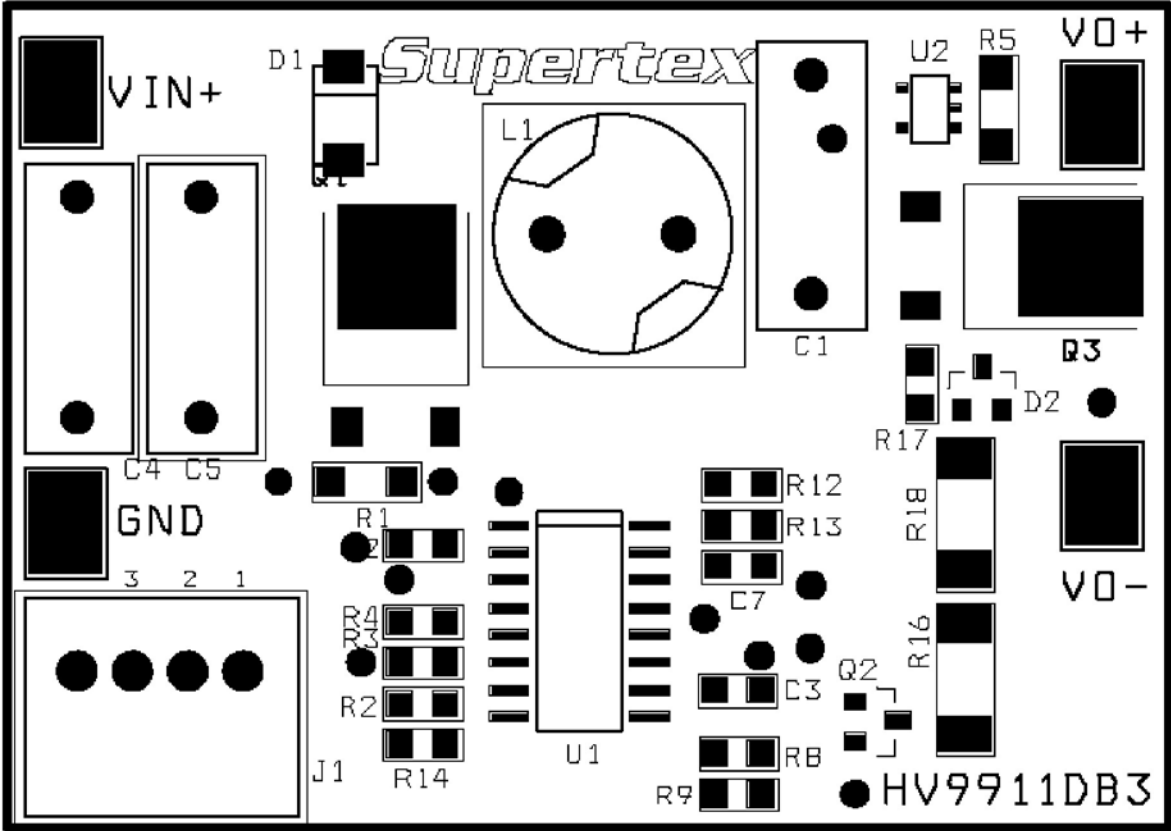

Bill of Materials

#	Qty	Ref Des	Description	Package	Manufacturer	Manufacturer's Part Number
1	2	C1, C4, C5	0.33 μ F, 100V metal film capacitors	Thru-Hole	Panasonic	ECQ-E2334KF
2	2	C2	1 μ F, 16V X7R ceramic chip capacitor	SMD0805	TDK Corp.	C2012X7R1C105K
3	1	C3	0.1 μ F, 16V X7R ceramic chip capacitor	SMD0805	Murata	GRM219R71C104KA01D
4	1	C7	47nF, 50V X7R ceramic chip capacitor	SMD0805	Kemet	C0805C473K5RACTU
5	1	D1	400V, 1.0A ultrafast recovery diode	SMB	ON Semi	MURS140T3
6	3	D2	9.1V, 350mW zener diode	SOT-23	Diodes Inc.	BZX84C9V1-7
7	1	J1	Side-entry 4-Pin male header	Thru-Hole	JST Sales Amer.	S4B-EH
8	4	J2, J3, J4, J5	Compact SMT test point	SMT	Keystone Electric	5016
9	1	L1	2.2mH, 0.41A sat, 0.5A rms inductor	SMA	Coilcraft	RFB1010-222L
10	2	Q1	250V, 1.1A N-Channel MOSFET	Thru-Hole	IR	IRFR224
11	1	Q2	240V, 15 Ω N-Channel MOSFET	SOT-23	Supertex	TN2124K1-G
12	1	Q3	400V, 1.8A P-Channel MOSFET	DPAK	IR	IRFR9214
13	1	R1	0.56 Ω , 1%, 1/4W chip resistor	SMD1206	Panasonic	ERJ-8RQFR56V
14	1	R2	604k Ω , 1%, 1/8W chip resistor	SMD0805	Yageo	RC0805FR-07604KL
15	1	R3	29.4k Ω , 1%, 1/8W chip resistor	SMD0805	Yageo	RC0805FR-0729K4L
16	1	R4	499 Ω , 1%, 1/8W chip resistor	SMD0805	Yageo	RC0805FR-07499RL
17	1	R5	1.24 Ω , 1%, 1/4W chip resistor	SMD1206	Yageo	RC1206FR-071R24L
18	1	R8	17.4k Ω , 1%, 1/8W chip resistor	SMD0805	Yageo	RC0805FR-0717K4L
19	1	R9	6.81k Ω , 1%, 1/8W chip resistor	SMD0805	Yageo	RC0805FR-076K81L
20	1	R12	16.2k Ω , 1%, 1/8W chip resistor	SMD0805	Yageo	RC0805FR-0716K2L
21	1	R13	8.66k Ω , 1%, 1/8W chip resistor	SMD0805	Yageo	RC0805FR-078K66L
22	1	R14	open	-	-	-
23	1	R16, R18	22k Ω , 1%, 1/2W chip resistor	SMD2010	Panasonic	ERJ-12ZYJ223U
24	1	R17	3.65k Ω , 1%, 1/8W chip resistor	SMD0805	Yageo	RC0805FR-073K65L
25	1	U1	Switchmode LED Driver with High Current Accuracy	SO-16	Supertex	HV9911NG-G
26	1	U2	High side current monitor	SOT-23	Supertex	HV7800K1-G

Supertex inc. does not recommend the use of its products in life support applications, and will not knowingly sell them for use in such applications unless it receives an adequate "product liability indemnification insurance agreement." **Supertex inc.** does not assume responsibility for use of devices described, and limits its liability to the replacement of the devices determined defective due to workmanship. No responsibility is assumed for possible omissions and inaccuracies. Circuitry and specifications are subject to change without notice. For the latest product specifications refer to the **Supertex inc.** (website: <http://www.supertex.com>)