

RN-42/RN-42-N Class 2 Bluetooth Module

Features

- Fully qualified Bluetooth® version 2.1 module, supports version 2.1 + Enhanced Data Rate (EDR)
- Backwards-compatible with Bluetooth version 2.0, 1.2, and 1.1
- Postage stamp sized form factor, 13.4 mm x 25.8 mm x 2 mm (RN-42) and 13.4 mm x 20 mm x 2 mm (RN-42-N)
- Low power (26 uA sleep, 3 mA connected, 30 mA transmit)
- UART (SPP or HCI) and USB (HCI only) data connection interfaces.
- Sustained SPP data rates: 240 Kbps (slave), 300 Kbps (master)
- HCI data rates: 1.5 Mbps sustained, 3.0 Mbps burst in HCI mode
- Embedded Bluetooth stack profiles included (requires no host stack): GAP, SDP, RFCOMM, and L2CAP protocols, with SPP and DUN profile support
- Bluetooth SIG certified
- Castellated SMT pads for easy and reliable PCB mounting
- Certifications: FCC, ICS, CE
- Environmentally friendly, RoHS compliant



- Measurement and monitoring systems
- Industrial sensors and controls
- Medical devices
- Computer accessories

Description

The RN-42 is a small form factor, low power, class 2 Bluetooth radio for designer's who want to add wireless capability to their products. The RN-42 supports multiple interface protocols, is simple to design in, and is fully certified, making it a complete embedded Bluetooth solution. The RN-42 is functionally compatible with the RN 41. With its high-performance, on-chip antenna and support for Bluetooth EDR, the RN-42 delivers up to a 3 Mbps data rate for distances up to 20 meters.

The RN-42 is also available in a package without an antenna (RN-42-N). Useful when the application requires an external antenna, the RN-42-N is shorter in length and has RF pads to route the antenna signal.

Applications

- Cable replacement
- Barcode scanners/readers

Figure 1. RN-42 Block Diagram

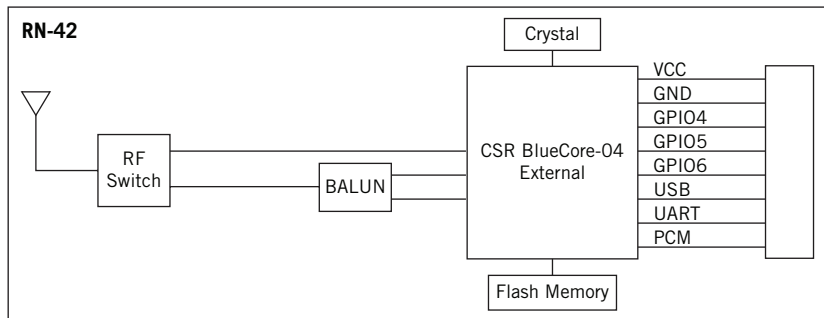

OVERVIEW

- Baud rate speeds: 1,200 bps up to 921 Kbps, non-standard baud rates can be programmed
- Class 2 radio, 60 feet (20 meters) distance, 4 dBm output transmitter, -80 dBm typical receive sensitivity
- Frequency 2,402 ~ 2,480 MHz
- FHSS/GFSK modulation, 79 channels at 1-MHz intervals
- Secure communications, 128-bit encryption
- Error correction for guaranteed packet delivery
- Configuration via the local UART and over-the-air RF
- Auto-discovery/pairing does not require software configuration (instant cable replacement)
- Auto-connect master, I/O pin (DTR), and character-based trigger modes

The module's moisture sensitivity level (MSL) is 1. Table 1 shows the module's size and weight.

Table 1. Module Size & Weight

Parameter	RN-42	RN-42-N	Units
Size	13.4 x 25.8 x 2	19 x 13.4 x 2	mm
Weight	0.045	0.040	Oz.

Tables 2 through 6 provide detailed specifications for the module.

Table 2. Environmental Conditions

Parameter	Value
Temperature Range (Operating)	-40° C ~ 85° C
Temperature Range (Storage)	-40° C ~ 85° C
Relative Humidity (Operating)	≤ 90%
Relative Humidity (Storage)	≤ 90%

Table 3. Digital I/O Characteristics

3.0 V ≤ VDD ≤ 3.3 V	Min.	Typ.	Max.	Units
Input Logic Level Low	-0.4	-	+0.8	V
Input Logic Level High	0.7 VDD	-	VDD + 0.4	V
Output Logic Level Low	-	-	0.2	V
Output Logic Level High	VDD - 0.2	-	-	V
All I/O pins (Except reset) Default to Weak Pull Down	+0.2	+1.0	+5.0	uA

Table 4. Electrical Characteristics

Parameter	Min.	Typ.	Max.	Units
Supply voltage (DC)	3.0	3.3	3.6	V
Average Power Consumption				
Radio ON (discovery or inquiry window time), <i>Note (1)</i>		40		mA
Connected Idle (no sniff)		25		mA
Connected Idle (sniff 100 ms)		12		mA
Connected with data transfer	40	45	50	mA
Deep sleep idle mode		26		uA

Notes:

- If, in slave mode, there are bursts of radio ON time that vary with the windows. Depending on how you set the windows, that determines your average current.

Table 5. Radio Characteristics

Parameter	Freq. (GHz)	Min.	Typ.	Max.	Bluetooth Specification	Units
Sensitivity at 0.1% BER	2.402	-	-80	-86	≤ -70	dBm
	2.441	-	-80	-86		dBm
	2.480	-	-80	-86		dBm
RF Transmit Power	2.402	0	2	4	≤ 4	dBm
	2.441	0	2	4		dBm
	2.480	0	2	4		dBm
Initial Carrier Frequency Tolerance	2.402	-	5	75	75	kHz
	2.441	-	5	75		kHz
	2.480	-	5	75		kHz
20dB bandwidth for modulated carrier		-	900	1,000	≤ 1000	kHz
Drift (Five slots packet)		-	15	-	40	kHz
Drift Rate		-	13	-	20	kHz
Δf _{1avg} Max Modulation	2.402	140	165	175	> 140	kHz
	2.441	140	165	175		kHz
	2.480	140	165	175		kHz
Δf _{2avg} Min Modulation	2.402	140	190	-	115	kHz
	2.441	140	190	-		kHz
	2.480	140	190	-		kHz

Table 6. Range Characteristics (Approximate Range In Office Environment)

Range	RN-42
After One Wall	55 feet
After Two Walls	60 feet
After Three Walls	36 feet

The readings shown in Table 6 are approximate and may vary depending upon the RF environment. Bluetooth hops in a pseudo-random fashion over the 79 frequencies in the ISM band to adapt to the interference. Data throughput and range vary depending on the RF interference environment.

Figure 2 shows the module's pinout and Table 7 describes the pins.

Figure 2. RN-42/RN-42-N Pinout

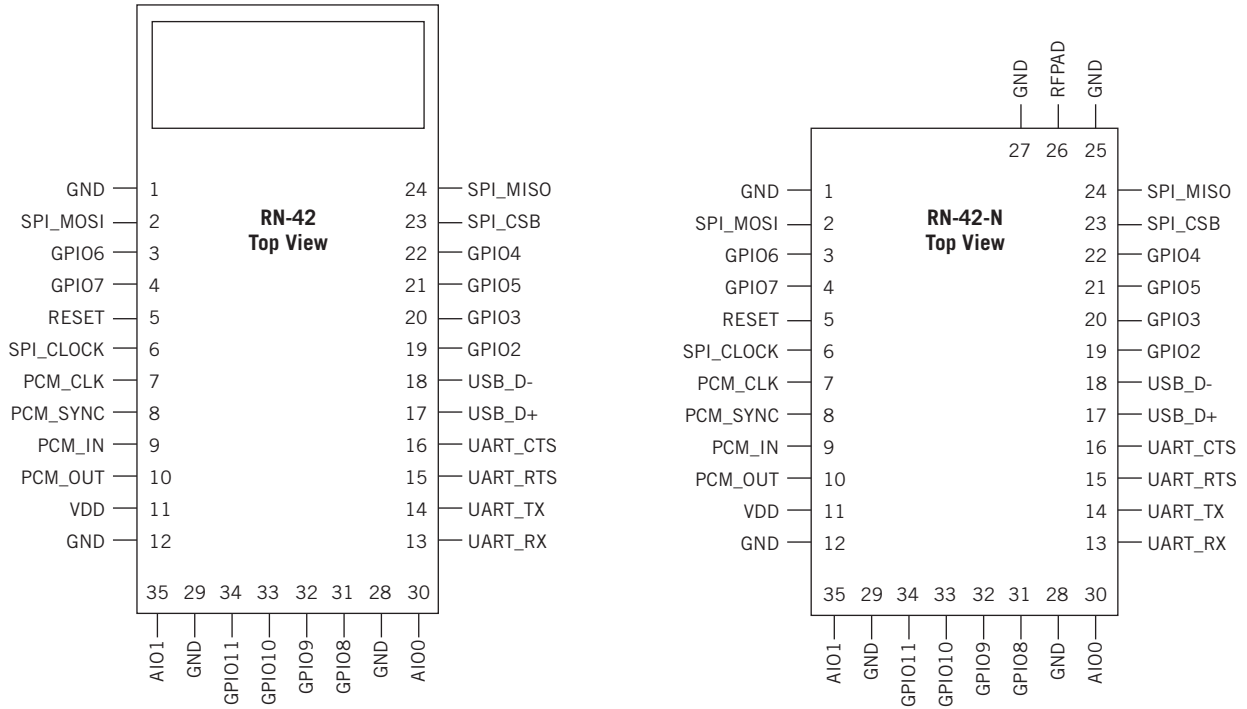

Table 7. Pin Description

Pin	Name	Description	Default	Voltage (V)
1	GND	Ground		0
2	SPI_MOSI	Programming only	No Connect	3
3	GPIO6	Set BT master (high = auto-master mode)	Input to RN-42 with weak pulldown	0 - 3.3
4	GPIO7	Set Baud rate (high = force 9,600, low = 115 K or firmware setting)	Input to RN-42 with weak pulldown	0 - 3.3
5	RESET	Active-low reset. Hold low for low-power operation.	Input to RN-42 with 1K pullup	
6	SPI_CLK	Programming only	No Connect	
7	PCM_CLK	PCM interface	No Connect	
8	PCM_SYNC	PCM interface	No Connect	
9	PCM_IN	PCM interface	No Connect	
10	PCM_OUT	PCM interface	No Connect	
11	VDD	3.3-V regulated power input		
12	GND	Ground		
13	UART_RX	UART receive Input	Input to RN-42	0 - 3.3
14	UART_TX	UART transmit output	High level output from RN-42	0 - 3.3
15	UART_RTS	UART RTS, goes high to disable host transmitter	Low level output from RN-42	0 - 3.3
16	UART_CTS	UART CTS, if set high, disables transmitter	Low level input to RN-42	0 - 3.3
17	USB_D+	USB port	Pull up 1.5 K when active	0 - 3.3
18	USB_D-	USB port		0 - 3.3

Pin	Name	Description	Default	Voltage (V)
19	GPIO2	Status, high when connected, low otherwise	Output from RN-42	0 - 3.3
20	GPIO3	Auto discovery = high	Input to RN-42 with weak pulldown	0 - 3.3
21	GPIO5	Status, toggles based on state, low on connect	Output from RN42	0 - 3.3
22	GPIO4	Set factory defaults	Input to RN-42 with weak pulldown	0 - 3.3
23	SPI_CSB	Programming only	No Connect	
24	SPI_MISO	Programming only	No Connect	
25	GND	Ground for RN-42-N		
26	RF Pad	RF pad for RN-42-N		
27	GND	Ground for RN-42-N		
30	AIO0	Optional analog input	Not Used	
31	GPIO8	Status (RF data Rx/Tx)	Output from RN-42	0 - 3.3
32	GPIO9	I/O	Input to RN-42 with weak pulldown	0 - 3.3
33	GPIO10	I/O (remote DTR signal)	Input to RN-42 with weak pulldown	0 - 3.3
34	GPIO11	I/O (remote RTS signal)	Input to RN-42 with weak pulldown	0 - 3.3
35	AIO1	Optional analog input	Not Used	

Figure 3 shows the module's physical dimensions.

Figure 3. RN-42/RN-42-N Physical Dimensions

All Dimensions Are In mm

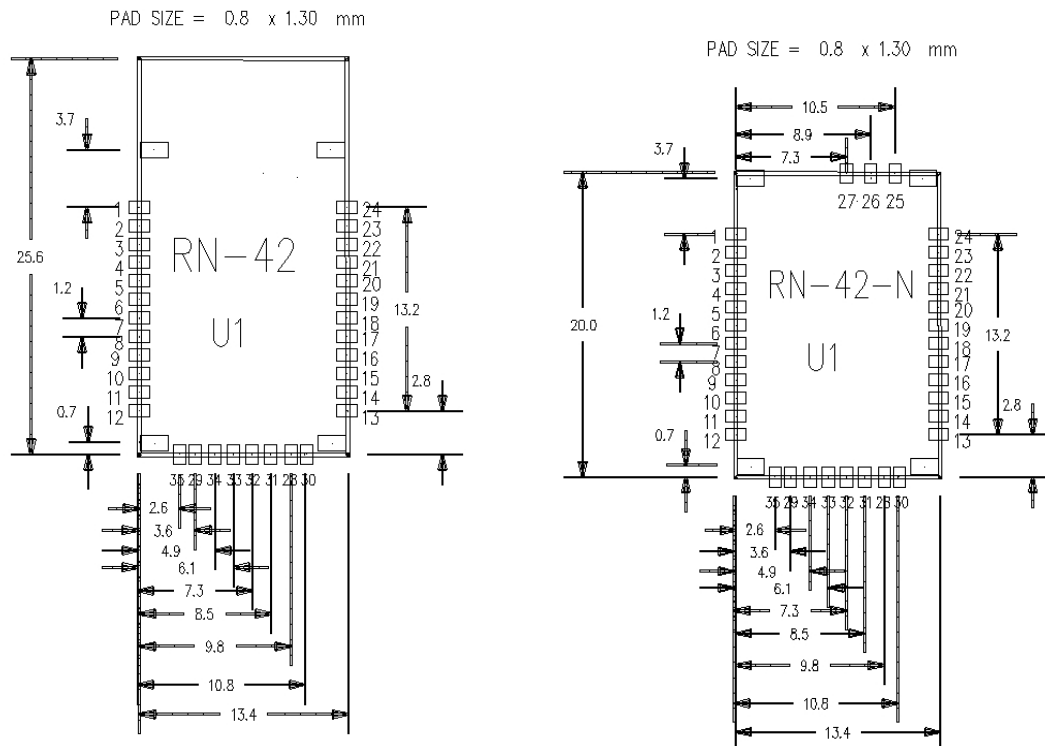

TYPICAL APPLICATION SCHEMATIC

Figure 4 shows a typical application schematic. Because the RN-41 and RN-42 are functionally compatible, this diagram applies to both modules.

Figure 4. Application Schematic

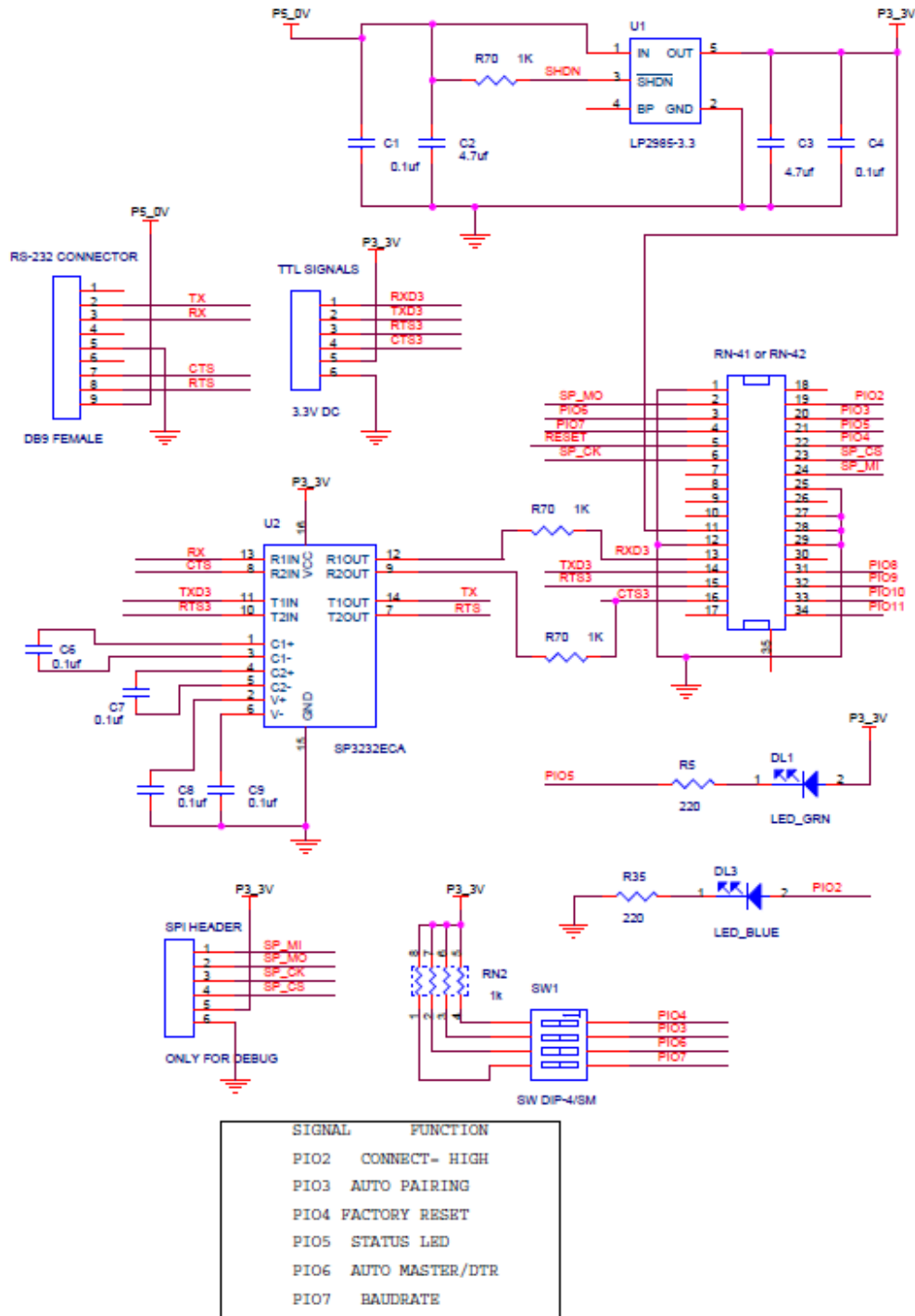

DESIGN CONCERNS

The following sections provide information on designing with the RN-42 module, including radio interference, factory reset, solder reflow profile, connection status, etc.

Reset Circuit

The RN-42 contains a 1k pullup to VCC, and the reset polarity is active low. The module's reset pin has an optional power-on-reset circuit with a delay, which should only be required if the input power supply has a very slow ramp or tends to bounce or have instability on power up. Often a microcontroller or embedded CPU I/O is available to generate the reset once power is stable. If not, designers can use one of the many low-cost power supervisor chips currently available, such as the MCP809, MCP102/121, and Torex XC61F.

Factory Reset Using GPIO4

Roving Networks recommends that designers connect the GPIO4 pin to a switch, jumper, or resistor so it can be accessed. This pin can be used to reset the module to its factory default settings, which is critical in situations where the module has been misconfigured. To reset the module to the factory defaults, GPIO4 should be high on power-up and then toggle low, high, low, high with a 1 second wait between the transitions.

Connection Status

GPIO5 is available to drive an LED, and it blinks at various speeds to indicate status (see Table 7). GPIO2 is an output that directly reflects the connection state as shown in Table 8.

Table 8. GPIO5 Status

GPIO5 Status	Description
Toggle at 1 Hz	The module is discoverable and waiting for a connection.
Toggle at 10 Hz	The module is in command mode.
High	The module is connected to another device over Bluetooth.

Table 9. GPIO2 Status

GPIO2 Status	Description
High	The module is connected to another device over Bluetooth.
Low	The module is not connected over Bluetooth.

HCI Mode

Roving Networks offers the Host Controller Interface (HCI) mode in addition to the standard operational mode of its Bluetooth modules (standard mode refers to the on-board stack running on the module).

In HCI mode, the on-board stack is bypassed and the module is put in a state that runs the Bluetooth baseband. The HCI provides a command reference interface to the baseband controller and the link manager, and provides access to the hardware status and control registers. This interface provides a uniform method for accessing the Bluetooth baseband capabilities.

In this mode, the Bluetooth stack is no longer on-board the module. It is offloaded to the interfacing host processor. The Bluetooth module is used as a radio, performing the lower level MAC functionalities, while the application stack runs on the host processor.

Using the module in HCI mode allows designers to implement profiles that are not natively supported on the Bluetooth module.

NOTE: HCI mode requires a separate firmware build that must be loaded into the module's flash at the factory. Is not upgradeable in the field.

Roving Networks offers HCI mode in two hardware interfaces:

- HCI over UART
- HCI over USB

HCI over UART

In this mode, the hardware interface between the host processor and the Bluetooth module is the UART. You must interface the flow control signals between the host processor and the Bluetooth module for the HCI interface to work. Failure to do so can cause the host processor and the Bluetooth module to become out of sync and break the Bluetooth link.

HCI over USB

In this mode, the hardware interface between the host processor and the Bluetooth module is the USB. In this architecture, the Bluetooth module is the USB slave and the host processor is the USB host.

Using the USB interface offers the advantage of a faster data link between the Bluetooth module and the host processor. With this architecture, it is possible to achieve Bluetooth's theoretical maximum throughput of 3 Mbps.

Low Power

To achieve low-power operation, hold the module's RESET pin low. With RESET = 0 VDC, the module consumes 35 uA of power. If RESET is left floating or high, the module consumes 3 mA in sleep mode. To obtain the lowest power, the RN-42 should be passive (in slave mode and not trying to make connections).

Using the SPI Bus to Upgrade the Flash Memory

While not required, this bus is very useful for configuring the Bluetooth modules' advanced parameters. The bus is required when upgrading the module's firmware. The typical application schematic shown in Figure 4 shows a 6-pin header that can be implemented to gain access to this bus. A minimum-mode version might simply use the SPI signals (4 pins) and obtain ground and VCC from elsewhere in the design.

Minimizing Radio Interference

When laying out the carrier board for the RN-42 module, the areas under the antenna and shielding connections should not have surface traces, ground planes, or exposed vias (see Figure 5). For optimal radio performance, the RN-42 module's antenna end should protrude at least 5 mm beyond any metal enclosure.

Figure 5. Minimizing Radio Interference

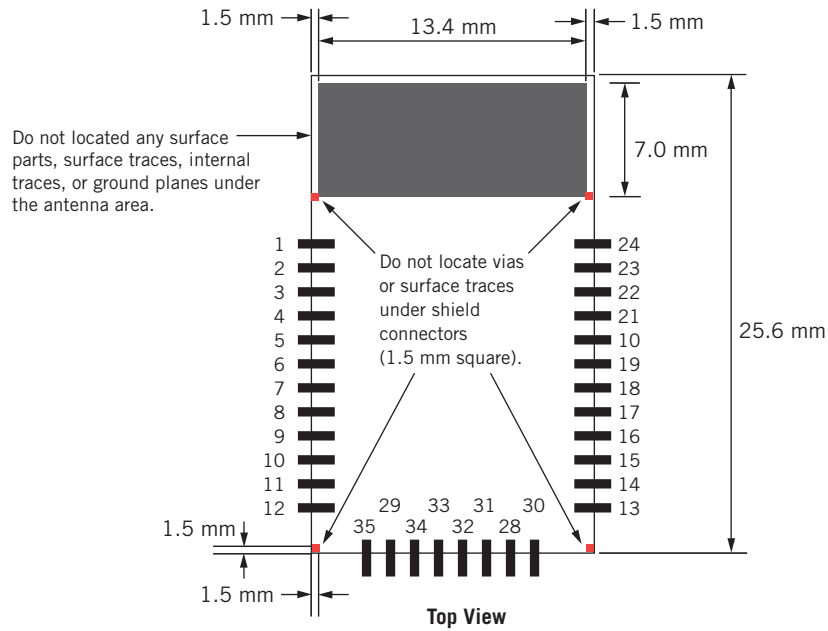

Because the RN-42-N does not contain an antenna, it does not carry regulatory approvals.

If designers use Roving Networks recommended design, they can file for a permissible antenna change and use Roving Networks' regulatory approvals. The recommended antenna design for the RN-42 is a PCB trace antenna. To meet the regulatory compliance information, customers must use the trace pattern shown in Figure 6.

Figure 6. Antenna Trace Pattern

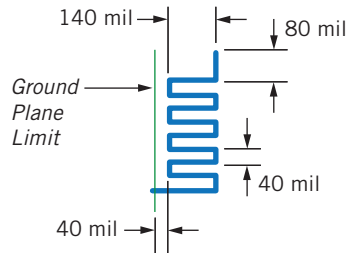

Trace Width Is 20 mil

If designers choose to use another antenna, they must go through the regulatory approval process.

Antenna Design

The pattern from the RF_OUT terminal pad should be designed with 50 ohms impedance and traced with straight lines (see Figure 7). The RF_OUT signal line should not run under or near the RN-21 module. The GND plane should be on the side of the PCB to which the module is mounted. GND should be reinforced with through-hole connections and other means to stabilize the electric potential.

Figure 7. Antenna Design

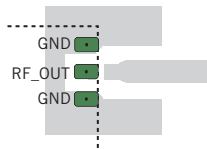

Solder Reflow Profile

The lead-free solder reflow temperature and times are:

- *Temperature*—230° C, 30 - 40 seconds, peak 250° C maximum
- *Preheat temperature*—165° ± 15° C, 90 to 120 seconds
- *Time*—Single pass, one time

COMPLIANCE INFORMATION

Table 10 describes the module's compliance information.

Table 10. Compliance Information

Category	Country	Standard
Radio	USA	FCC Part 15 Subpart B: 2008 Class B
		FCC CRF Title 47 Part 15 Subpart C
	FCC ID:	T9J-RN42
	Europe	ETSI EN 301 489-1 V1.8.1
		ETSI EN 301 489-17 V2.1.1
		ETSI EN 300 328 V1.7.1
	Canada	IC RSS-210 low power comm. device
Certification Number:	6514A-RN42	
EMC	USA	FCC CFR47 Part 15 subclass B
	Europe	EN 55022 Class B radiated
		EN61000-4-2 ESD immunity
		EN61000-4-3 radiated field
		EN61000-4-6 RF immunity
		EN61000-4-8 power magnetic immunity
Bluetooth	BQB LISTED	B014867- SPP and DUN profiles
Environmental	RoHS	RoHS compliant

ORDERING INFORMATION

Table 11 provides ordering information.

Table 11. Ordering Information

Part Number	Description
RN-42	Standard application firmware (SPP/DUN master and slave).
RN-42-HCI	HCI firmware (HCI over H4 UART).
RN-42-USB	USB firmware (HCI over USB port, slave device at 12-Mbps rate).
RN-42-N	Standard application firmware (SPP/DUN master and slave) without antenna.
For other configurations, contact Roving Networks directly.	

Go to <http://www.rovingnetworks.com> for current pricing and a list of distributors carrying Roving Networks products.

Roving Networks, Inc.
102 Cooper Court
Los Gatos, CA 95032
+1 (408) 395-5300
www.rovingnetworks.com

Copyright © 2012 Roving Networks. All rights reserved. Roving Networks is a registered trademark of Roving Networks. Apple Inc., iPhone, iPad, iTunes, Made for iPhone are registered trademarks of Apple Computer.

Roving Networks reserves the right to make corrections, modifications, and other changes to its products, documentation and services at any time. Customers should obtain the latest relevant information before placing orders and should verify that such information is current and complete.

Roving Networks assumes no liability for applications assistance or customer's product design. Customers are responsible for their products and applications which use Roving Networks components. To minimize customer product risks, customers should provide adequate design and operating safeguards.

Roving Networks products are not authorized for use in safety-critical applications (such as life support) where a failure of the Roving Networks product would reasonably be expected to cause severe personal injury or death, unless officers of the parties have executed an agreement specifically governing such use.