



MIC4833 Evaluation Board

Low Noise Dual 220 V_{pp} EL Driver With Output Voltage Slew Rate Control

General Description

The MIC4833 is a low noise dual Electroluminescent (EL) Panel driver used in backlighting applications. The MIC4833 converts a low DC voltage to a high DC voltage using a boost converter and then alternates the high DC voltage across the EL panels using an H-bridge. The MIC4833 incorporates internal wave-shaping circuitry specifically designed to reduce audible noise emitted by EL panels. The two EL panels may be dimmed by applying a PWM signal to the device.

An external resistor may be used to adjust the output voltage slew rate to reduce audible noise. The MIC4833 features separate oscillators for the boost and H-bridge stages to allow independent control. External resistors set the operating frequencies of each stage allowing the EL circuit to optimize efficiency and brightness.

Requirements

The MIC4833 evaluation board requires an input power source that is able to deliver greater than 400mA at 2.3V.

Precautions

The evaluation board does not have reverse polarity protection. Applying a negative voltage to the V_{IN} terminal may damage the device. The MIC4833 is a high voltage, low current device and should be handled with care.

Getting Started

1. **Connect an external supply to V_{IN}.** Apply desired input voltage to the V_{IN} (J1) and ground terminal (J2) of the evaluation board, paying careful attention to polarity and supply voltage ($2.3V \leq V_{IN} \leq 5.8V$). An ammeter may be placed between the input supply and the V_{IN} terminal to the evaluation board. Ensure that the supply voltage is monitored at the V_{IN} terminal. The ammeter and/or power lead resistance can reduce the voltage supplied to the input.
2. **Connect EL panel(s).** Connect one EL panel between the ELA (J3) and COM (J5) terminals. Connect another EL panel

between the ELB (J4) and COM (J5) terminals if desired. Note that polarity of the EL panel does not matter.

3. **Enable/Disable the MIC4833 Boost Regulator.** JP3 is the enable/disable jumper for the Boost Regulator portion of the MIC4833. Connecting JP3-to-ground disables the boost regulator and connecting JP3 to V_{IN} enables the boost regulator. A voltage signal may be applied to the center pin of JP3 to enable or disable the boost regulator. A low voltage signal (0V) will disable the boost regulator, while a high voltage equal to V_{IN} will enable the boost regulator. The enable voltage should rise and fall between high and low monotonically without interruptions.
4. **Enable/Disable the MIC4833 H-Bridge.** JP4 is the enable/disable jumper for the H-Bridge portion of the MIC4833. Connecting JP4 to ground disables the H-Bridge and connecting JP4 to V_{IN} enables the H-Bridge. Disabling the H-Bridge does not disable the boost regulator.
5. **Enable/Disable the EL Panel Individually.** Both the Boost Regulator and the H-Bridge of the MIC4833 must be enabled in order for the EL panel to illuminate. Remove the ENA (JP1) and ENB (JP2) jumpers to disable EL Panel A and Panel B, respectively. For minimum shutdown current, both the Boost Regulator and the H-Bridge should be turned off as well.

Ordering Information

Part Number	Description
MIC4833YML EV	220Vpp EL Driver, 3mm x 3mm MLF [®] Evaluation Board

MLF and MicroLeadFrame are a registered trademark of Amkor Technology.

Micrel, Inc. • 2180 Fortune Drive • San Jose, CA 95131 • USA • tel + 1 (408) 944-0800 • fax 1 (408) 474-1000 • <http://www.micrel.com>

April 2009

M9999-043009
(408) 955-1690

Boost Regulator Output Voltage

The boost regulator output voltage is set to 110V. The output peak-to-peak voltage across the EL panel is approximately two times the boost regulator output voltage (220V_{PP}).

Switching Frequency

The switching frequency of the converter is controlled by an external resistor (R1) connected between RSW and VDD. The switching frequency increases as the resistor value decreases. In general, the lower the switching frequency, the greater the input current is drawn to deliver more power to the output. Lower switching frequencies can be used to drive larger panels. However, the switching frequency should not be so low as to allow the voltage at the switch node or the CS pin to exceed the absolute maximum voltage of those pins. For resistor value selections, see Table 2 on Page 3 or use the equation below. The switching frequency range is 35kHz to 350kHz, with an accuracy of ±20%.

$$f_{sw} \text{ (kHz)} = \frac{46}{R1 \text{ (M}\Omega\text{)}}$$

EL Frequency

The EL panel frequency is controlled by an external resistor (R2) connected between REL and VDD pin. The panel frequency increases as the resistor value decreases. In general, as the EL panel frequency increases, the amount of current drawn from the battery will increase. The EL panel brightness is dependent upon its frequency. For resistor value selections, see Table 2 on page 3 or use the equation below. The EL panel frequency range is 100Hz to 1500Hz, with an accuracy of ±20%.

$$f_{EL} \text{ (Hz)} = \frac{425}{R2 \text{ (M}\Omega\text{)}}$$

Enable Function

There are a few different ways to enable and disable the MIC4833. The R1 resistor can be pulled to VDD or ground to enable or disable the boost regulator, respectively. This turns off both the EL panels by cutting power to the device completely. If R1 is not pulled all the way to VDD, then the frequency set by R1 will be different than the programmed value. Similarly, the R2 resistor can be pulled to VDD or ground to enable or disable the H-bridge. It must also be pulled all the way to VDD so that the EL frequency is equal to its programmed value.

For individual panel control, the ENA and ENB pins can be used to enable ELA and ELB, respectively.

Pulling ENA or ENB high (above 1.2V) or low (below 0.4V) will turn ELA and ELB panels on or off.

PWM Dimming

The MIC4833 may be dimmed by adding a shunt capacitor (C_{PWM}) to the REL pin, shown in Figure 1. The duty cycle of the PWM signal changes the frequency of the EL panel, thereby changing its brightness. Increasing the PWM duty cycle increases the EL frequency to a maximum set by R2 (Duty Cycle = 100%). Decreasing the PWM duty cycle decreases the EL frequency. The PWM duty cycle should not be lowered to a level that may cause the EL frequency to be lower than 100Hz, since EL frequencies lower than 100Hz may cause the panel to flicker. The frequency of the PWM signal can range from 500Hz to 50kHz. The peak voltage of the PWM signal should be equal to VDD. The evaluation board does not provide a footprint to add this capacitor.

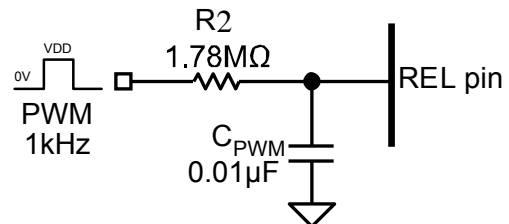

Figure 1. PWM Dimming Circuit

Slew Resistor

The MIC4833 is designed to reduce audible noise in EL panels by the use of the internal wave-shaping circuit. To further reduce audible noise, a Slew Resistor (R5) can be added to limit the rate of change of the EL driver output voltage by limiting the output current. A slower rate of change in voltage across the EL panel creates less physical distortion in the material and therefore reduces the amount of audible noise. The lower the I_{SLEW}, the slower the output voltage will change across the EL panels. If R5 is not used, the I_{SLEW} is by default 5mA, equivalent to using a 22kΩ for R_{SLEW}.

R5	I _{SLEW}
Open	5mA
125kΩ	1mA
22kΩ	5mA
10kΩ	10mA

Table 1. Slew Resistor Setting

Evaluation Board Schematic

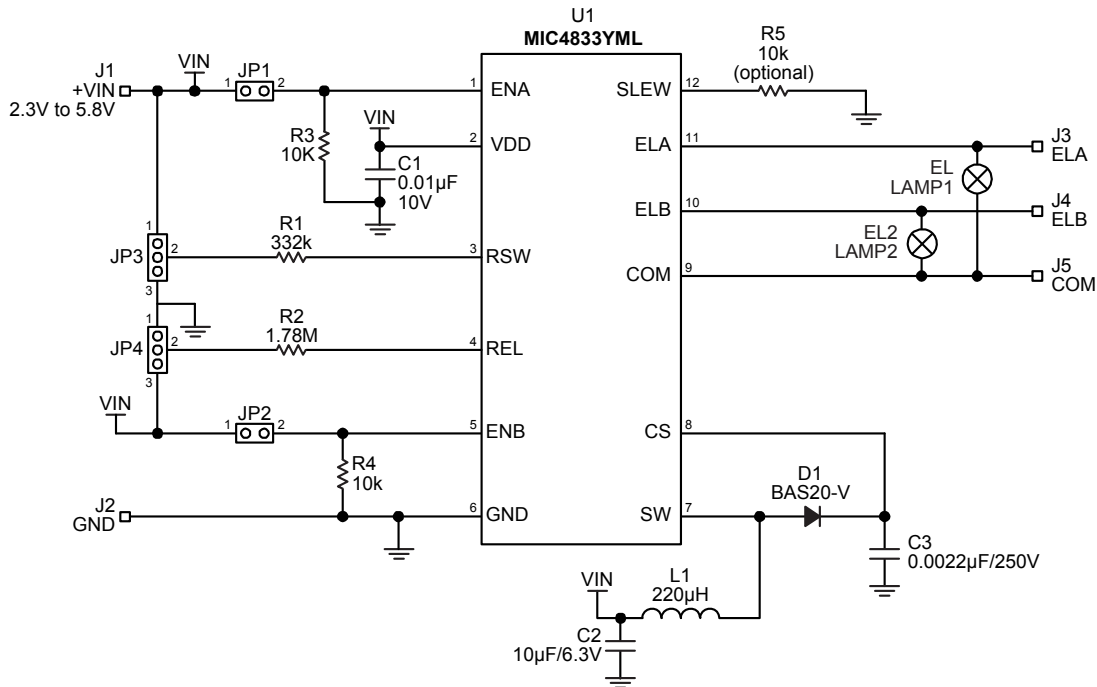

Figure 2: Typical Li-Ion Powered MIC4833 Circuit

Note: Table 2 applies to circuit shown in Figure 2.

Total Panel Area (inch ²)	Capacitance (nF)	Panel Frequency (Hz)	150	200	250	300	350	400	500
			R2 (MΩ)	2.80	2.10	1.69	1.40	1.21	1.05
0.4	2	R1 (kΩ)	324	340	357	383	392	402	442
		f _{sw} (kHz)	138	132	126	118	116	112	102
1	5	R1 (kΩ)	357	365	392	422	442	475	511
		f _{sw} (kHz)	125	122	116	108	102	95	88
2	10	R1 (kΩ)	402	453	487	549	590	649	681
		f _{sw} (kHz)	112	100	92	83	76	70	66
3	15	R1 (kΩ)	464	511	590	698	768	909	1000
		f _{sw} (kHz)	98	88	77	65	58	50	45
4	20	R1 (kΩ)	523	665	750	909	1000	1000	
		f _{sw} (kHz)	86	68	60	50	45	45	
5	25	R1 (kΩ)	619	825	909	1000			
		f _{sw} (kHz)	72	55	50	45			
6	30	R1 (kΩ)	698	953	1000				
		f _{sw} (kHz)	65	47	45				
8	40	R1 (kΩ)	1000						
		f _{sw} (kHz)	45						

Table 2: Recommended R1 & R2 Values for Various Total Panel Sizes

Bill of Materials

Item	Part Number	Manufacturer	Description	Qty
C1	C1608X7R1A103K	TDK ⁽¹⁾	0.01 μ F Ceramic Capacitor, 10V, X7R, Size 0603	1
C2	C1608X5R0J106K	TDK ⁽¹⁾	10 μ F Ceramic Capacitor, 6.3V, X5R, Size 0603	1
C3	C2012C0G2E2222J	TDK ⁽¹⁾	0.0022 μ F Ceramic Capacitor, 250V, C0G, Size 0805	1
L1	VLS4012T-221M	TDK ⁽¹⁾	220 μ H, 210mA I _{SAT} . (4mmx4mmx1.2mm)	1
D1	BAS20-V-GS18	Vishay ⁽²⁾	200V/200mA Hi-Voltage Switching Diode	1
R1	CRCW06033323FKEYE3	Vishay ⁽²⁾	332k Ω , 1%, 1/16W, Size 0603	1
R2	CRCW06031784FKEYE3	Vishay ⁽²⁾	1.78M Ω , 1%, 1/16W, Size 0603	1
R3, R4	CRCW06031002FKEYE3	Vishay ⁽²⁾	10k Ω , 1%, 1/16W, Size 0603	2
R5				Optional
U1	MIC4833YML	Micrel ⁽³⁾	Low Noise 12-pin 3mm x 3mm MLF [®] Dual 220Vpp EL Driver with Output Slew Control	1

Notes:

1. TDK: www.tdk.com
2. Vishay: www.vishay.com
3. Micrel, Inc.: www.micrel.com

Printed Circuit Board Layout

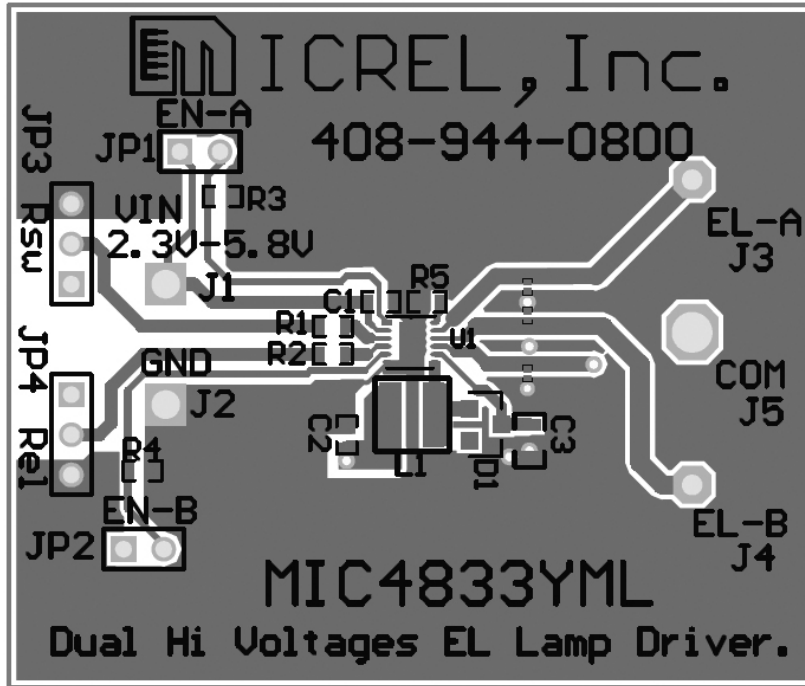

Top Layer

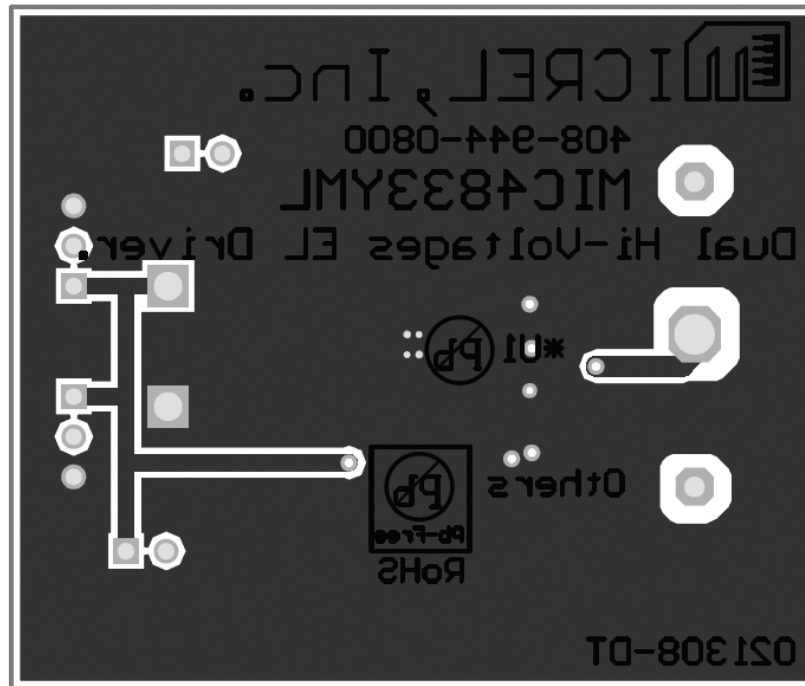

Bottom Layer

MICREL, INC. 2180 FORTUNE DRIVE SAN JOSE, CA 95131 USA
TEL +1 (408) 944-0800 FAX +1 (408) 474-1000 WEB <http://www.micrel.com>

The information furnished by Micrel in this data sheet is believed to be accurate and reliable. However, no responsibility is assumed by Micrel for its use. Micrel reserves the right to change circuitry and specifications at any time without notification to the customer.

Micrel Products are not designed or authorized for use as components in life support appliances, devices or systems where malfunction of a product can reasonably be expected to result in personal injury. Life support devices or systems are devices or systems that (a) are intended for surgical implant into the body or (b) support or sustain life, and whose failure to perform can be reasonably expected to result in a significant injury to the user. A Purchaser's use or sale of Micrel Products for use in life support appliances, devices or systems is a Purchaser's own risk and Purchaser agrees to fully indemnify Micrel for any damages resulting from such use or sale.

© 2007 Micrel, Incorporated.